

WESLOC

CLIPPED DUCTING



STRAIGHT DUCTS



Dia mm	Gauge mm	Weight kg/m
80	0.8	1.8
100	0.8	2.2
120	0.8	2.6
140	0.8	3.0
150	0.8	3.2
160	0.8	3.4
180	0.8	3.8
200	0.8	4.3
225	0.8	4.8
250	0.8	5.3
275	0.8	5.8
300	0.8	6.3
350	0.8	7.4

Dia mm	Gauge mm	Weight kg/m
400	1.0	10.0
450	1.0	10.0
500	1.0	12.5
550	1.2	15.9
600	1.2	17.3
650	1.2	18.8
700	1.2	20.2
750	1.2	21.7
800	1.6	32.4
850	1.6	35.4
900	1.6	37.5
950	1.6	39.6
1000	1.6	41.7

Also available in stainless steel and aluminium
For thicker tube upto 6mm wall see our Helixweld leaflet

TELESCOPIC DUCTS



Standard lengths
for telescopic
ducts

Min Length	Max Length
0.5 metres	0.75 metres
0.75 metres	1.1 metres
1.0 metres	1.4 metres

Special lengths
on request

BENDS

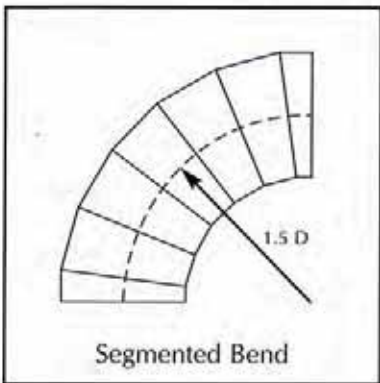
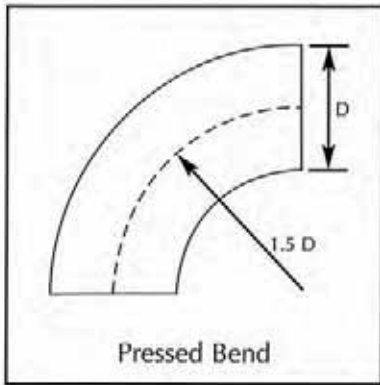

Pressed Bends available in 90, 60, 45, 30 & 15 Degree Forms				Segmented bends available in all sizes, angles and gauges upto 1,6mm
dia mm	thickness mm	dia mm	thickness mm	
80	0.9	180	1.0	
100	1.0	200	1.0	
120	1.0	225	1.0	
140	1.0	250	1.0	
150	1.0	275	1.0	
160	1.0	300	1.0	

ACCESS DOORS AND SIGHT GLASSES



Access doors to suit the application.

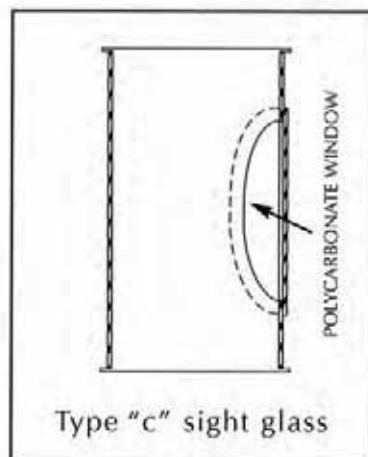
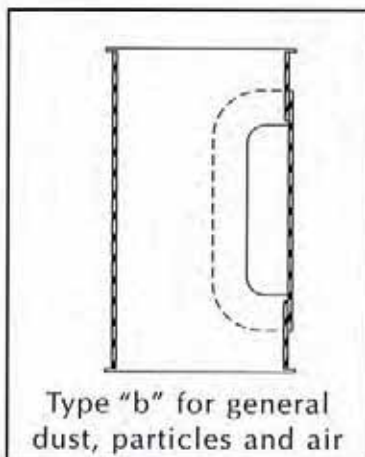
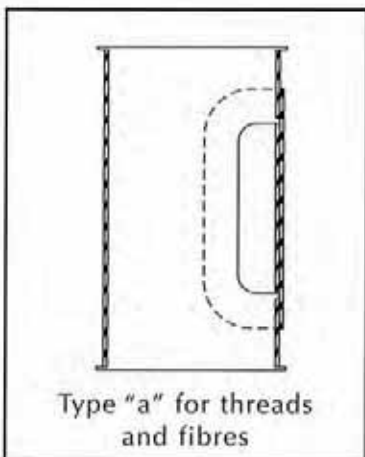

TAPERS, BRANCHES, TEES AND Y PIECES

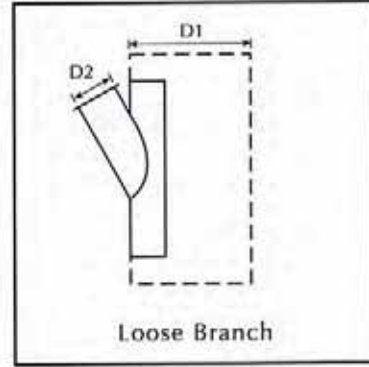
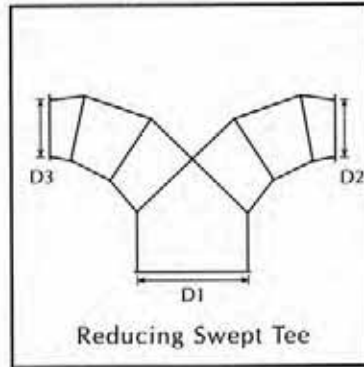
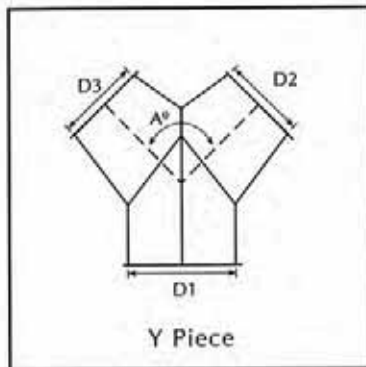
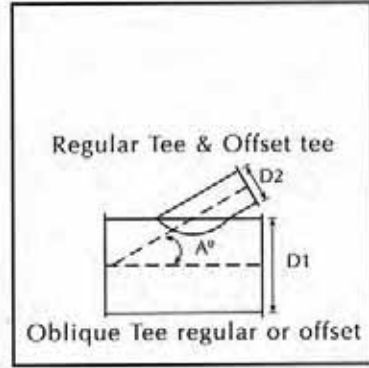
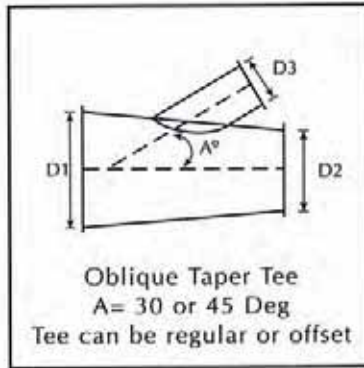
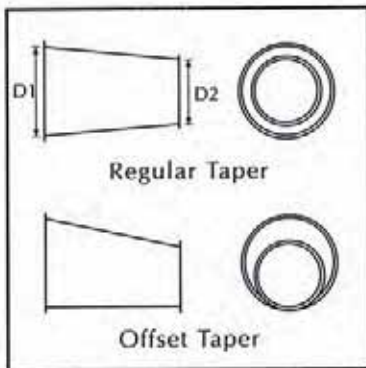

DAMPER, THROTTLE VALVES AND DIVERTER VALVES

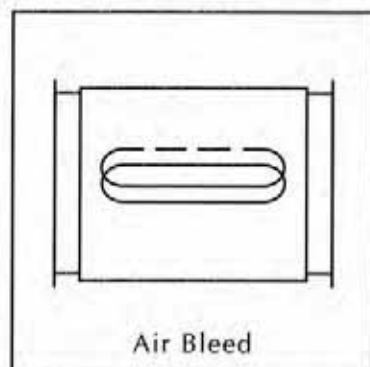
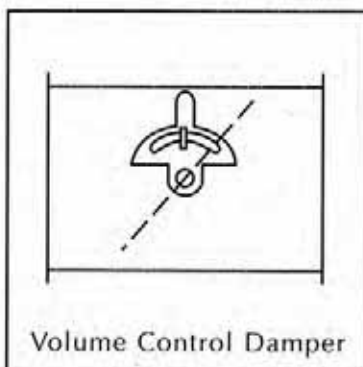
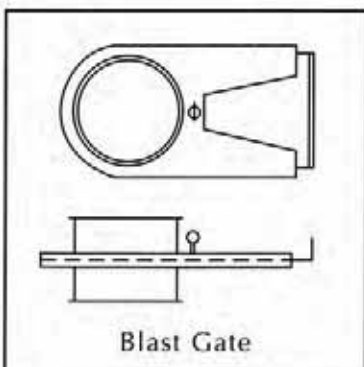
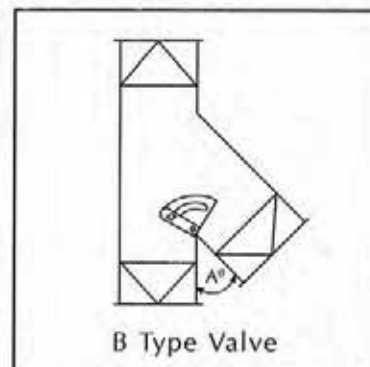
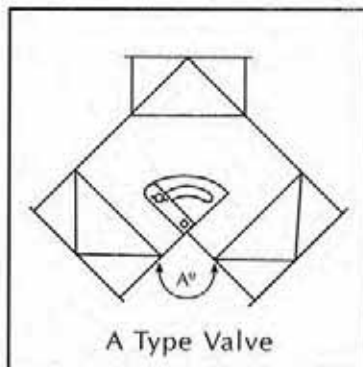
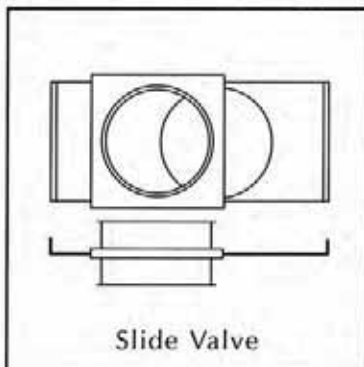
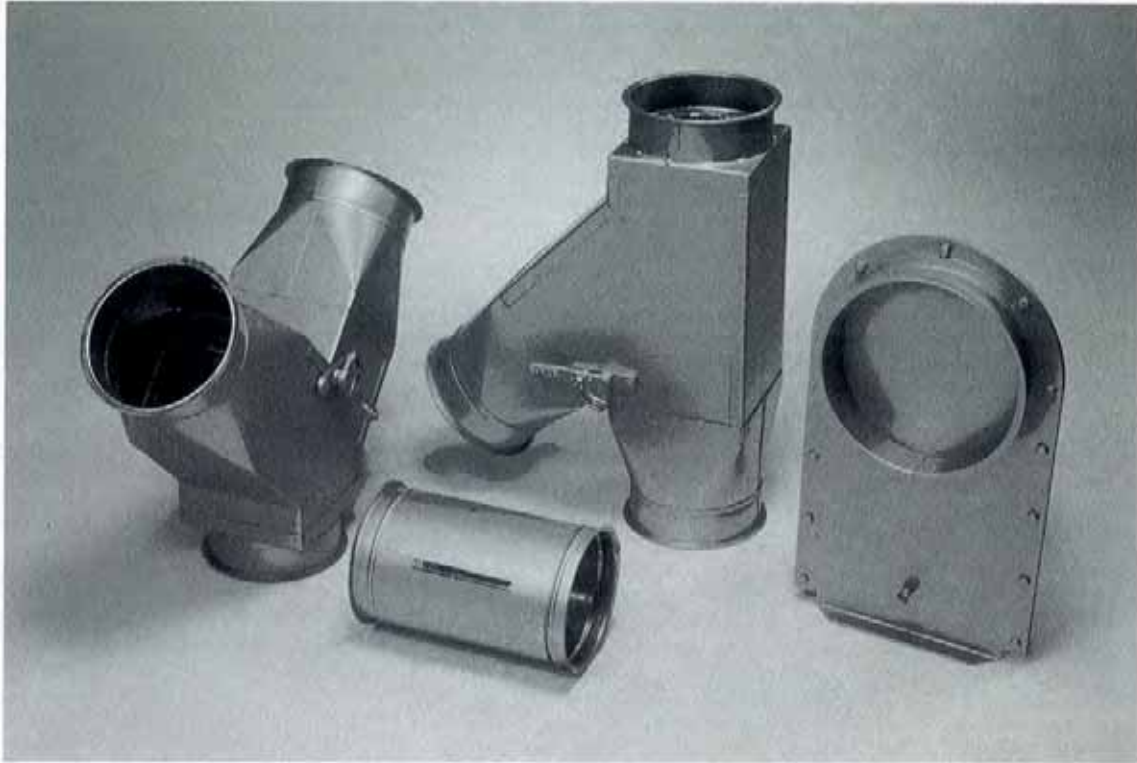

RECTANGULAR TO ROUNDS, CONE CAPS, JET COWLS, SWEEP UP BOXES, HOODS AND SPUTNIKS

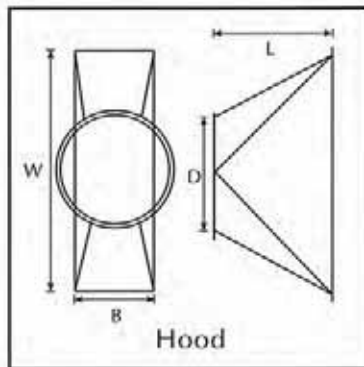
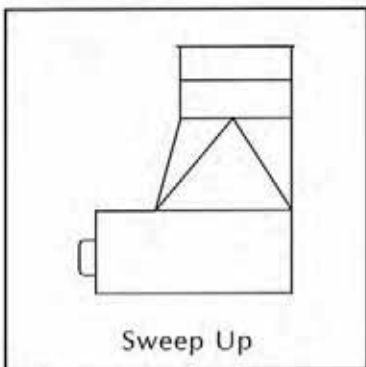
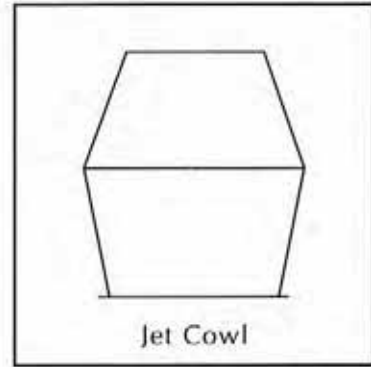
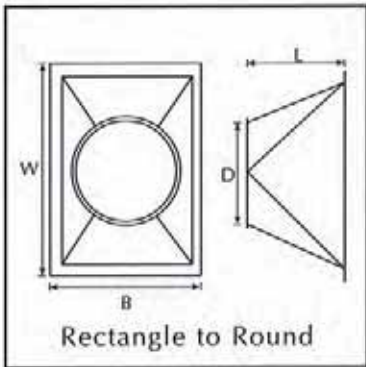

CLIPS, FLANGES AND SUPPORT RINGS

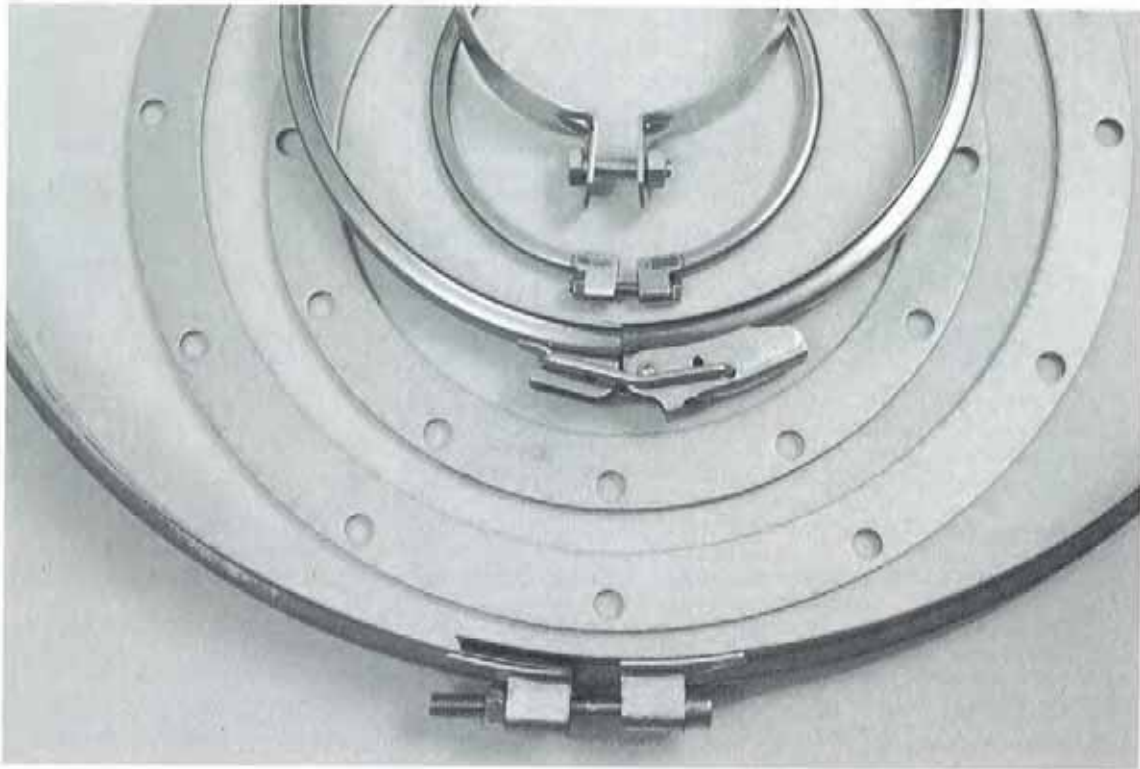

Tube size	PR	AC	QR	WC	A	B	C	D	E
80	✓	✓	✓		133	3	8	9	115
100	✓	✓	✓		153	3	8	9	135
120	✓	✓	✓		173	3	8	9	155
125	✓	✓	✓		178	3	8	9	160
140	✓	✓	✓		193	3	8	9	175
150	✓	✓	✓		203	5	8	9	185
160	✓	✓	✓		213	5	8	9	195
180	✓	✓	✓		233	5	8	9	215
200	✓	✓	✓		253	5	12	9	235
225	✓	✓	✓		278	5	12	9	260
250	✓	✓	✓		303	5	12	9	285
275	✓	✓	✓		328	5	12	9	303
300	✓	✓	✓		354	5	12	9	336
350	✓	✓	✓	✓	414	6	12	11	389
400	✓	✓	✓	✓	464	6	16	11	439
450	✓	✓	✓	✓	515	6	16	11	489
500	✓	✓	✓	✓	565	6	16	11	540
550			✓	✓	615	6	16	11	590
600			✓	✓	665	6	16	11	640
650			✓	✓	715	6	24	11	690
700			✓	✓	785	6	24	11	750
750			✓	✓	835	6	24	11	800
800			✓	✓	885	6	24	11	850
850			✓	✓	935	6	24	11	900
900			✓	✓	985	6	24	11	950
950			✓	✓	1035	6	24	11	1000
1000			✓	✓	1085	6	24	11	1050

